



# PRODUCT CATALOGUE 2020

EFFECTIVE: January 2020



Featuring

**THIRD WAVE**  
technology



[www.vsaent.com](http://www.vsaent.com)

# THIRD WAVE technology

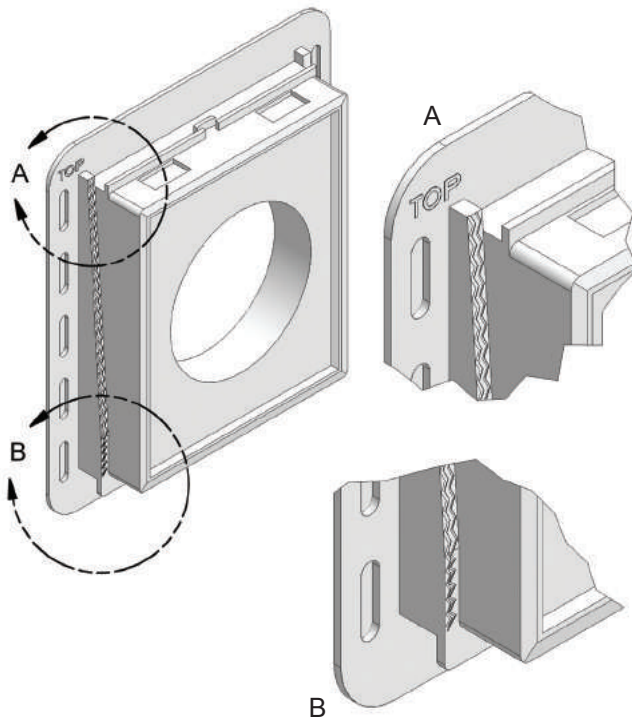

## “THIRD WAVE” Rain Screen Series of Siding Accessories

The Third Wave (rain screen) series of siding accessories addresses the need of the multiple siding exterior applications used in today’s residential homes. Third Wave Technology features engraved rain channels that incorporate the principal of surface tension. Water, as it cascades down the surface of the wall, is diverted to each side, down the engraved rain channels, and out over the exterior finish by means of the bottom rain flange.

## Rain Screen Technology

Laboratory tests show the Third Wave Technology products outperform every other siding accessory on the market. In the W-3 Water Wall test applications, Third Wave products eliminated or greatly reduced water penetration, even at 10 US gallons per hour, without the addition of peel and stick, caulking or building paper as recommended in exterior wall applications.

## UV Protected Material

VSA products are constructed of UV-protected, virgin polypropylene which is known for its durability in both hot and cold climates. The product remains pliable and color-fast for many years.

## Reversible Trim for Multiple Cladding Systems

There are no unnecessary openings in the nailing flange. The snap-over trim ring fits over the solid base without compromising any openings. It is adjustable, by reversible means, to accommodate 5/8”, 3/4”, 1” and 1¼” (1.59cm to 3.18cm) finished wall thickness for a variety of exterior cladding types. The removable trim rings allow for future maintenance checks.

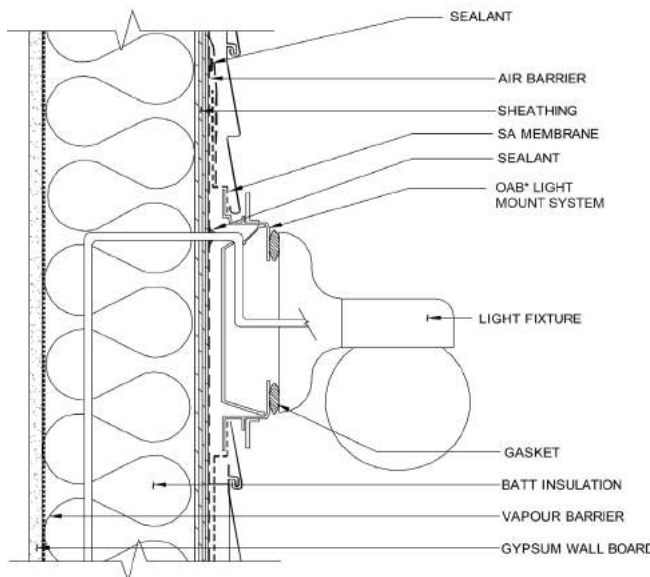

### OAB\* Light Mount System

United States Patent No. 5,664,375 and 7,358,440.  
Additional U.S. and Canadian patents pending.

\*Over Air Barrier technology



# EXTERIOR MOUNTING BLOCKS

## Original Series • SQUARE CORNER



Description	Number Code/Colour
<b>Plug Plate (PBP)</b>	101 White

**Contractors Choice - Canada's Original Series Plug Plate**  
**SPECIAL BULK PURCHASE AVAILABLE**



Description	Number Code/Colour
<b>4" x 6" Utility Plate (UPP)</b>	101F White

- Available with centre holes, Specify: 1/2", 5/8", 3/4", 1", 1 1/4", 1 1/2" & 2 1/2"
- Ideal for round wall penetrations: water lines, gas pipes, plumbing drains and electrical fittings

**Contractors' Choice - Canada's Original Series Utility Plate**



Description	Number Code/Colour
<b>Light Plate (LBP)</b>	201 White

- Standard 4" round opening

**Contractors Choice' - Canada's Original Series Utility Plate**  
**SPECIAL BULK PURCHASE AVAILABLE**



Description	Number Code/Colour
<b>7" x 7" Utility Plate (ULP)</b>	201F White

- Available with centre hole: 3 5/8" Round Opening, (O.D. 3" ABS Pipe)
- Multiple options for openings to 4 1/2"

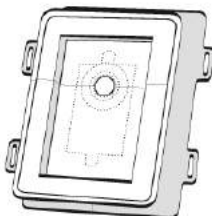

Description	Number Code/Colour
<b>Split Recessed Plug Water Plate (SRPW)</b>	5001 White

- Split face applications for existing pipe penetrations, ideal for water pipe applications.
- Three part Electrical Plug / Water Pipe mold pre-trimmed to 5/8", 3/4", 1" & 1 1/2".

# EXTERIOR MOUNTING BLOCKS

## Original Series • SQUARE CORNER

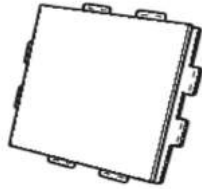

Description	Number Code/Colour
<b>Meter Mount Plate</b>	645080-01 White

- The solution for Electrical Meter Mount Backing Plate
- Outside dimensions: 17 5/8" x 15 7/8", designed to interlock to create larger surface.

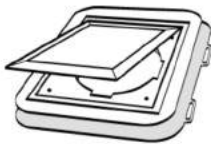

Description	Number Code/Colour
<b>4" Dryer Vent (4DV)</b>	1201 White (Vent face only)
	1441 Four Pack (4 Vents complete with four 4" pipes)
<b>3" Dryer Vent (3DV)</b>	1301 White (Vent face only)
	1341 Four Pack (4 Vents complete with four 3" pipes)

- Non-obtrusive vent door, bevelled edges for wind deflection.
- No cross louvers to obstruct the flow of exhaust - easy access to remove lint build-up.

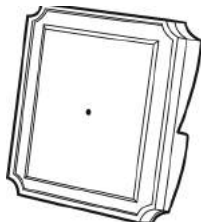

Description	Number Code/Colour
<b>Surface Series Block "Add A Light" Double 5" Bevel</b>	641060-00

- "Add A Light" surface mount mounting block with multiple siding styles including bevel: Double 5", Double 4.5", Double 4" & Triple 3" PLUS Dutch Lap.



Description	Number Code/Colour
<b>Bell Trap Drain, Square 6"</b>	1504-03 Grey Base & Lid

- ABS - Grey - Solvent Weld, Fits over 1-1/2" or into 2" Hub Connection



<b>Bell Trap Drain Lid</b>	1504L-03 Lid Only
----------------------------	-------------------

- Bell Trap Lid - 4-1/2" round, fits into Bell Trap Drain base and/or as replacement for metal base drain cover.

# EXTERIOR MOUNTING BLOCKS

## Original Series • SQUARE CORNER



Description	Number Code/Colour
<b>6" Wall Vent (6WV)</b>	301 White (vent only)
<b>Attachable Adaptor Collar Only</b> (available upon request)	300R - 6"
<b>Adaptor Collar Only</b> (available upon request)	6010-00 4" & 5"
<b>Combo Pack</b>	1331

- 6" Wall Vent with Attached 6" Adaptor Collar Make-up Air - Fresh Air Intake Vent designed for gas furnace, hot water tank, fireplace, heaters and air conditioning;
- Air Flow Specifications Available. See: Warnock Hersey Test Results # 1/93/07/13



Description	Number Code/Colour
<b>Screened Plastic Mini Louvers (PML)</b>	
<b>1"</b> net free area 0.20 sq in	PML101 White/104 Dk Brown
<b>1.5"</b> net free area 0.80 sq in	PML151 White/154 Dk Brown
<b>2"</b> net free area 1.50 sq in	PML201 White/204 Dk Brown
<b>2.5"</b> net free area 1.75 sq in	PML251 White/254 Dk Brown
<b>3"</b> net free area 2.76 sq in	PML301 White/304 Dk Brown
<b>4"</b> net free area 4.80 sq in	PML401 White/404 Dk Brown
<b>5"</b> net free area 6.67 sq in	PML501 White/504 Dk Brown
<b>6"</b> net free area 9.21 sq in	PML601 White/604 Dk.Brown

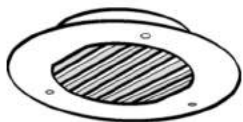

Description	Number Code/Colour
<b>4" Round Soffit Vent (4SV)</b>  <i>Vent Free Area: 6.38 sq. in.</i>	601 White
	606 Brown
	604S Optional Screen

- Full 1" back collar for mechanical connection. Full 1" flange for easy installation over soffit.
- Manufactured without screen to suit 1/4" bird screen, exhaust requirements, 604S (8"x8") screen available.

# EXTERIOR ACCESSORIES

## “Third Wave” Self Flashing Series

VSA's Third Wave Technology is a water diversion system. Using a rain gutter and surface tension, water is directed from the top of the accessory, down the sides, and out over the exterior membrane by means of a bottom drip channel. Properly installed, it eliminates or greatly reduces the penetration of water into the cavity between the exterior membrane and the weather barrier of the building.

“THIRD WAVE” accessories accommodate thickness depths of 5/8”, 3/4”, 1” & 1¼” (1.59cm to 3.18cm)

**THIRD WAVE**   
**technology**

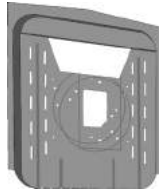

### RAIN SCREEN SPACERS - simplify installation!

Taking only minutes to install, this labour and cost saving spacer works with all Third Wave siding accessories and is suitable for use with 1/2” or 3/4” strapping.

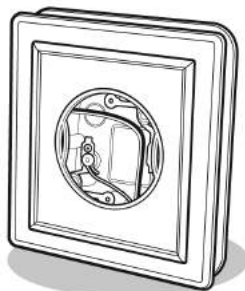
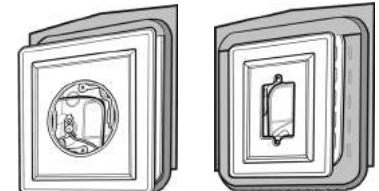

Description	Number Code/Colour
<b>“Over Air Barrier” Electrical Light Mounting Block</b>  	26458-01 White
	26458-02 Black
	26458-25 Tumbleweed
	26458-28 Wicker
	26458-29 Khaki
	26458-54 Clay
	26458-55 Storm
Complete with Rain Screen Spacer	26460

• Overall Dimensions: 7 1/2” x 8 1/2” • Base Dimensions: 5 1/2” x 6 1/2”

ETL tested to CSA/UL for wet locations. • Electrical base CSA/UL equivalent for 18 cubic inches



Description	Number Code/Colour
<b>“Over Air Barrier” Electrical Plug Mounting Block</b>  	26158-01 White
	26158-02 Black
	26158-25 Tumbleweed
	26158-28 Wicker
	26158-29 Khaki
	26158-54 Clay
	26158-55 Storm
Complete with Rain Screen Spacer	26160

• Overall Dimensions: 5 3/4” x 7 3/8” • Base Dimensions: 4” x 5 3/4”

ETL tested to CSA/UL for wet locations. • Electrical base CSA/UL equivalent for 18 cubic inches

# EXTERIOR ACCESSORIES

## “Third Wave” Self Flashing Series

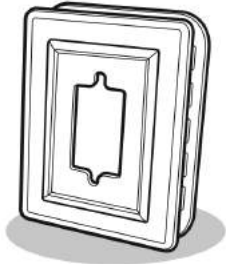

Description	Number Code/Colour
<b>Flush Plug</b>	21158-01 White
	21158-02 Black
	21158-25 Tumbleweed
	21158-28 Wicker
	21158-29 Khaki
	21158-54 Clay
	21158-55 Storm
<b>Complete with Rain Screen Spacer</b>	21160

- Standard, Flush Plug Electrical Plate.
- Overall Dimensions: 5 3/4" x 7 3/8" • Base Dimensions: 4" x 5 3/4"

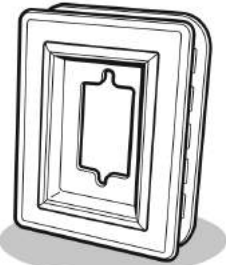

Description	Number Code/Colour
<b>Recessed Plug</b>	21258-01 White
	21258-02 Black
	21258-25 Tumbleweed
	21258-28 Wicker
	21258-29 Khaki
	21258-54 Clay
	21258-55 Storm
<b>Complete with Rain Screen Spacer</b>	21260

- Renovation friendly protection from the elements.
- Overall Dimensions: 5 3/4" x 7 3/8" • Base Dimensions: 4" x 5 3/4"

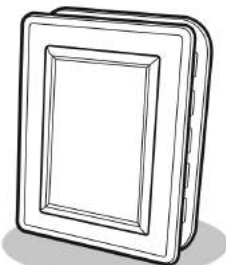

Description	Number Code/Colour
<b>3x5 Mount</b>	21358-01 White
	21358-02 Black
<b>Complete with Rain Screen Spacer</b>	21360

- Ideal for use as a railing mount. Installation details available.
- Overall Dimensions: 5 3/4" x 7 3/8" • Base Dimensions: 4" x 5 3/4"

# EXTERIOR ACCESSORIES

## “Third Wave” Over Air Barrier Electrical Mounting Blocks

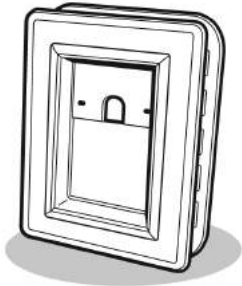

Description	Number Code/Colour
<b>Recessed Split Water</b>	21758-01 White
	21758-02 Black
	21758-25 Tumbleweed
	21758-28 Wicker
	21758-29 Khaki
	21758-54 Clay
	21758-55 Storm
<b>Complete with Rain Screen Spacer</b>	21760

- Features removable inserts to fit over and under the water system or any protrusion.
- Overall Dimensions: 5 3/4" x 7 3/8" • Base Dimensions: 4" x 5 3/4"

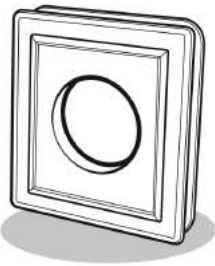

Description	Number Code/Colour
<b>Light Mount</b>	21458-01 White
	21458-02 Black
	21458-25 Tumbleweed
	21458-28 Wicker
	21458-29 Khaki
	21458-54 Clay
	21458-55 Storm
<b>Complete with Rain Screen Spacer</b>	21460

- Features a 4" opening for electrical mount.
- Overall Dimensions: 7 1/2" x 8 1/2" • Base Dimensions: 5 1/2" x 6 1/2"

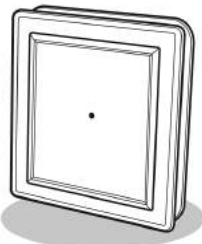

Description	Number Code/Colour
<b>Surface Mount</b>	21558-01 White
<b>Complete with Rain Screen Spacer</b>	21560

- Features 1/4" centre opening. • Available in white only.
- Overall Dimensions: 7 1/2" x 8 1/2" • Base Dimensions: 5 1/2" x 6 1/2"



Description	Number Code/Colour
<b>5x6 Mount</b>	21658-01 White
<b>Complete with Rain Screen Spacer</b>	21660

- Available in white only. • Ideal for use as a railing mount. Installation details available.
- Overall Dimensions: 7 1/2" x 8 1/2" • Base Dimensions: 5 1/2" x 6 1/2"



# EXTERIOR ACCESSORIES

## Vinyl Handrail Cover & Accessories

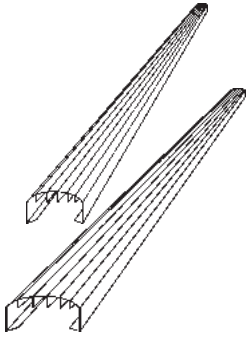

Description	Number Code/Colour
<b>Handrail Cover 2"x4"</b>	12401 White
	12402 Sandalwood
<b>Handrail Cover 2"x6"</b>	12601 White
	12602 Sandalwood

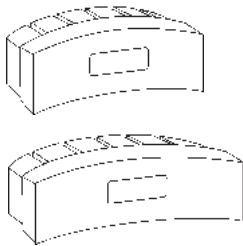

Description	Number Code/Colour
<b>End Cap 2"x4"</b>	10241 White
	10242 Sandalwood
<b>End Cap 2"x6"</b>	10261 White
	10262 Sandalwood

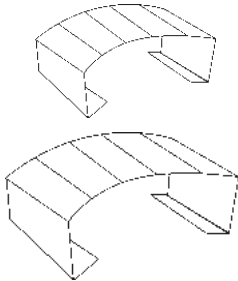

Description	Number Code/Colour
<b>Sleeve 2"x4"</b>	9241 White
	9242 Sandalwood
<b>Sleeve 2"x6"</b>	9261 White
	9262 Sandalwood

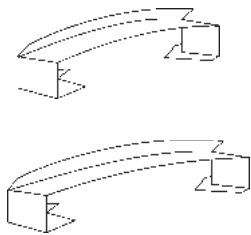

Description	Number Code/Colour
<b>Corner Cap 2"x4"</b>	8241 White
	8242 Sandalwood
<b>Corner Cap 2"x6"</b>	8261 White
	8262 Sandalwood

Description	Number Code/Colour

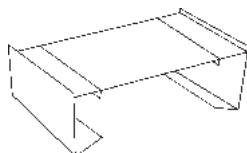

Description	Number Code/Colour
<b>Plant Holder 2"x6"</b>	6261 White
	6262 Sandalwood

## EXTERIOR ACCESSORIES

### Decorative Gable Vents

#### DECORATIVE GABLE VENTS - *The contractor's choice!*

- Include level lines to assist in the installation
- Applications include wood, brick, vinyl, hardy board, aluminum, etc.
- Square and rectangle designs include the same features as rounds and octagons
- Maximize vent free air flow for each vent

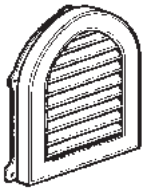

Description	Number Code/Colour
<b>Cathedral Gable Vent - 22"x28"</b> <i>Vent Free Area: 107 sq. in.</i>	626110-00 White

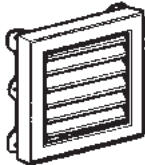

Description	Number Code/Colour
<b>Square Gable Vent - 18"x18"</b> <i>Vent Free Area: 44 sq. in.</i>	626045-00 White

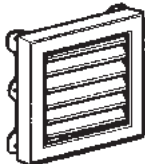

Description	Number Code/Colour
<b>Square Gable Vent - 12"x12"</b> <i>Vent Free Area: 44 sq. in.</i>	626043-00 White



Description	Number Code/Colour
<b>Rectangular Gable Vent - 18"x24"</b> <i>Vent Free Area: 74 sq. in.</i>	626080-00 White

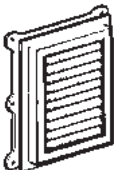

Description	Number Code/Colour
<b>Small Rectangular Gable Vent - 12x18</b> <i>Vent Free Area: 74 sq. in.</i>	626075-00 White

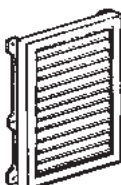

Description	Number Code/Colour
<b>Large Rectangular Gable Vent - 22x28</b> <i>Vent Free Area: 118 sq. in.</i>	626120-00 White

# EXTERIOR ACCESSORIES

## Decorative Gable Vents

### DECORATIVE GABLE VENTS - *The contractor's choice!*

- All vents include a decorative drip channel ideal for rain screen applications — it funnels water out and over the exterior finish; weeping holes prevent condensation or moisture from being trapped.
- Large rear flange allows easy flashing and peel-and-stick application; removable 3" trim ring allows easy installation
- Deep wood grain finish complete with mitre joints enhances the original wood vent look
- Molded-in screen prevents insects from nesting; screen cannot become unglued

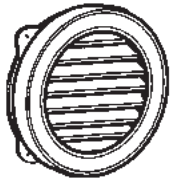

Description	Number Code/Colour
<b>Round Gable Vent - 22"</b> <i>Vent Free Area: 55 sq. in.</i>	626055-00 White

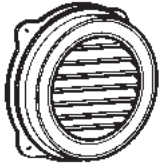

Description	Number Code/Colour
<b>Round Gable Vent - 18"</b> <i>Vent Free Area: 55 sq. in.</i>	626053-00 White



Description	Number Code/Colour
<b>Octagon Gable Vent - 22"</b> <i>Vent Free Area: 58 sq. in.</i>	626060-00 White



Description	Number Code/Colour
<b>Octagon Gable Vent - 18"</b> <i>Vent Free Area: 55 sq. in.</i>	626058-00 White



Description	Number Code/Colour
<b>Half Moon Gable Vent - 22"x34"</b> <i>Vent Free Area: 111 sq. in.</i>	626095-00 White
<b>Half Moon Gable Vent - 18"x30"</b> <i>Vent Free Area: 96 sq. in.</i>	626093-00 White

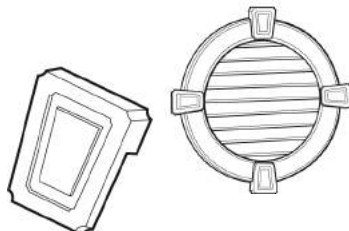

Description	Number Code/Colour
<b>Key Stone Blocks</b>	641080-00 White

- Easy mounting on all styles and sizes of Duraflo Decorative Gable Products.

# A leader since 1987, we know EXTERIOR BUILDING PRODUCTS.



“VSA is a Canadian company, with manufacturing in North America and distribution throughout the world.”

*“VSA’s Third Wave product stands alone. It’s amazing how well it works to redirect water from penetrating the exterior envelope.”—Bryce Davies, GM, Insul-Twin Systems Ltd.*

*“Third Wave Series of products demonstrate greatly improved water shedding performance over standard siding accessories.”—Dave Fookes, P.Eng., Project Engineer, Morrison Hershfield Limited*